

Technical Data Sheet

360-0017 Shorting Link, Non-Insulated, .040 (1,02) diameter pins

(For insulated version see 461-2871, 461-2872 and 461-3771)

Both leg lengths are to be within .010 [0.25] of each other.

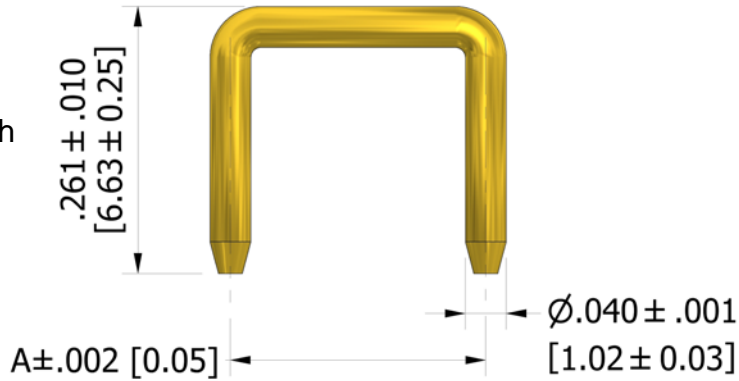

How to order code
360-0017-XX-03-00
Basic Part No XX = A dimension

DIMENSIONS	
Dash No (XX)	A Dimension
-01	.200 (5,08)
-02	.250 (6,35)
-03	.300 (7,62)
-04	.400 (10,16)
-05	.500 (12,70)

MATERIALS		
Component	Material	Finish(-03)
Pin	Brass	Gold over Nickel



Dimensions in inches [mm]