

Technical Data Sheet

558-1192, Variable Coil, Shielded, Vertical, .080μH thru 1.20mH (533-1738 Form)

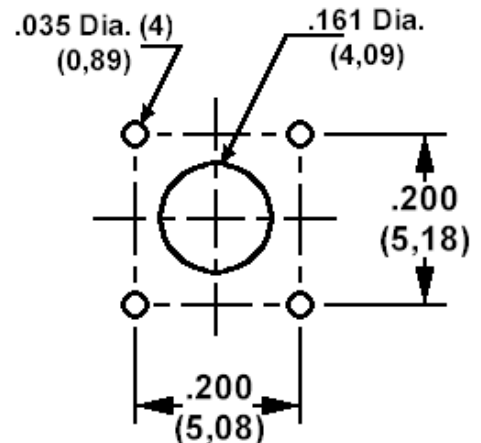
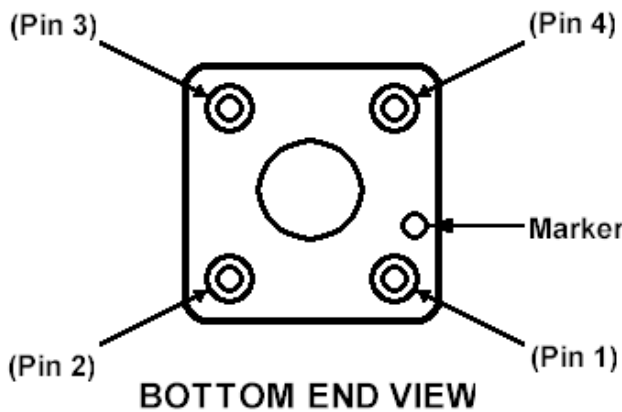
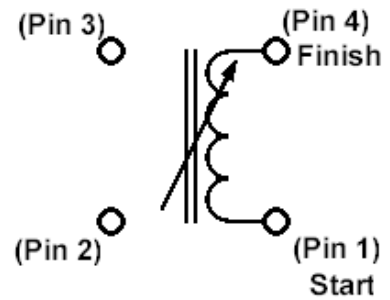
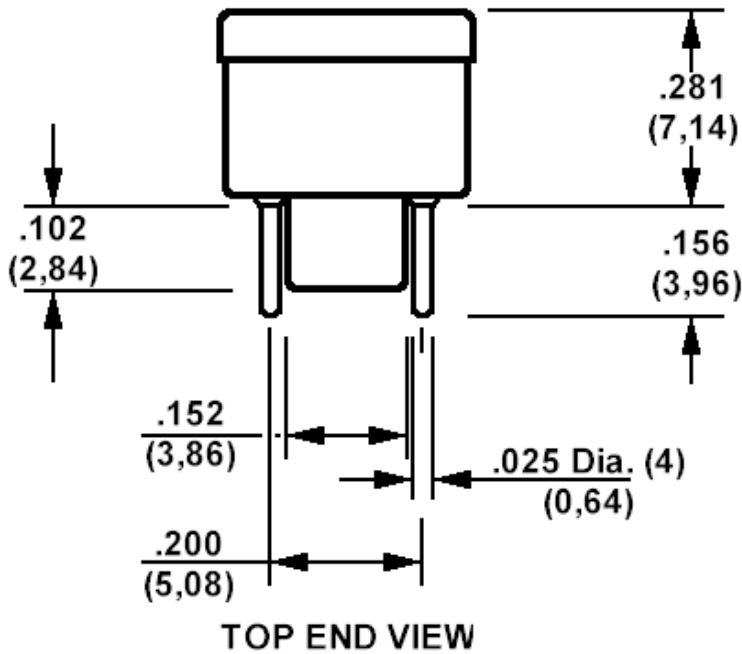
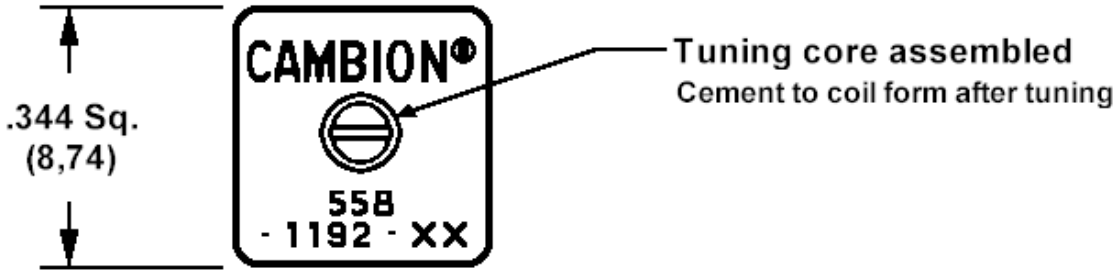

How to order code**558-1192-XX-00-00****Basic Part No (XX = Inductance range identifier. See table for options)**

Basic Part No.	XX	Inductance L (μH)		Q Min. @ L Min	Q Min. @ L Max	Test Freq. (MHz)	DCR Max. (Ω)	DC Max. (mA)	SRF Min. (MHz)
		Min.	Max.						
558-1192	-01	.08	.12	50	65	25.0	.05	1300	250.0
	-02	.12	.18	55	70	25.0	.06	1200	250.0
	-03	.18	.27	55	70	25.0	.10	1100	250.0
	-04	.27	.39	60	70	25.0	.12	950	240.0
	-05	.39	.56	60	70	25.0	.20	700	215.0
	-06	.56	.82	55	60	25.0	.45	540	180.0
	-07	.82	1.2	50	45	25.0	.50	450	146.0
	-08	1.2	1.8	35	40	7.90	.70	375	120.0
	-09	1.8	2.7	40	45	7.90	1.0	300	100.0
	-10	2.7	3.9	40	45	7.90	1.5	230	81.0
	-11	3.9	5.6	30	40	7.90	1.7	230	43.0
	-12	5.6	8.2	25	40	7.90	1.9	210	32.0
	-13	8.2	12.0	25	40	7.90	2.0	200	22.0
	-14	12.0	18.0	35	50	2.50	2.7	180	21.0
	-15	18.0	27.0	40	50	2.50	3.5	160	16.0
	-16	27.0	39.0	40	50	2.50	4.5	150	14.0
	-17	39.0	56.0	40	50	2.50	5.5	140	11.0
	-18	56.0	82.0	40	50	2.50	6.5	130	9.5
	-19	82.0	120.0	30	40	2.50	10.0	120	8.0
	-20	120.0	180.0	25	30	.790	14.0	80	6.0
	-21	180.0	270.0	25	30	.790	20.0	75	5.0
	-22	270.0	390.0	25	30	.790	28.0	70	4.0
	-23	390.0	560.0	25	30	.790	38.0	60	3.5
	-24	560.0	820.0	25	30	.790	48.0	50	3.0
	-25	820.0	1200.0	25	30	.790	65.0	40	2.4

Core and Cup Core Material is:-

- 01 thru -07 Carbonyl SF (Blue)
- 08 thru -19 Carbonyl E (Red)
- 20 thru -25 Carbonyl C (Yellow)

Windings are varnish impregnated and powdered iron components are moisture proofed

Temperature range: -55°C to +125°C

Dimensional Tolerance (unless otherwise stated) - ± .005 (0,13)

Recommended tuning tool - 435-1880-01-00-00